

Detailing Model Trucks

Detailing Clint Freeman Components' Caterpillar 3406E diesel engine

by KEN SMITH

In 1993, Caterpillar introduced its 3406E diesel engine with an electronic engine management system and horsepower ratings ranging from 310-500. The 3406E engine offers truckers 14-liter power and advanced electronic technology, a first for Caterpillar. That combination translates into increased fuel economy, improved reliability, and top performance.

In this and the next installment of "Detailing Model Trucks," we will detail Clint Freeman Components' 1/25 scale Caterpillar 3406E engine kit (no. EK-8). The kit consists of 29 separate cast-resin parts. The alternator and fan blade are not supplied, but they can be ordered separately from CFC.

In this issue, we will install the right- and left-side engine sensors, turbocharger oil lines, and alternator.

PRE-ASSEMBLY. Take time to read CFC's instruction sheet, and wash all of the parts with mild soap and lukewarm water to remove any casting residue. Let the parts dry, then sand the mating surfaces to ensure a better glue bond.

ENGINE ASSEMBLY. Photo 1 depicts the complete Caterpillar 3406E kit as received from CFC. For this project, we will also add accessory brackets (part no. AP-2106) and an A/C compressor (part no. 4003) from Accu-Pro; linkage hardware, braided line, fitting line, and machined-aluminum fittings from Detail Master (part nos. DM 2420, 1301, 1311, 1313, 1303, 3041, 3042, and 3043, respectively); and a cast-resin alternator from CFC (part no. EP-10).

Figure 1 illustrates the assembly sequence of the right side of the Caterpillar 3406E engine, while Figure 2 shows the left-side assembly sequence. Start by using Figures 1 and 2 as a guide to assemble part numbers 1, 2, 5, 8, 9, 11-13, and 25-29. The remaining parts will be assembled later.

ENGINE SENSOR/HARNESS ASSEMBLY.

Refer to Figure 3 and carefully examine the locations of the eight engine-mounted sensors and the injector connector. The engine sensors are connected to the engine control module (ECM) by the electrical harness shown in Figure 3. We'll depict the fuel temperature sensor, engine speed/timing sensor, intake manifold air temperature sensor, intake manifold pressure sensor, boost pressure sensor, atmospheric pressure sensor, coolant temperature sensor, oil pressure sensor, and the injector connector. These sensors, injector connector, and electrical harness must be attached to the engine before we can proceed.

We'll use Detail Master's adapter fittings (no. 3043) for the sensors, Detail Master braided line no. 1301 for the electrical leads, and Detail

FIGURE 1 RIGHT SIDE ENGINE COMPONENTS

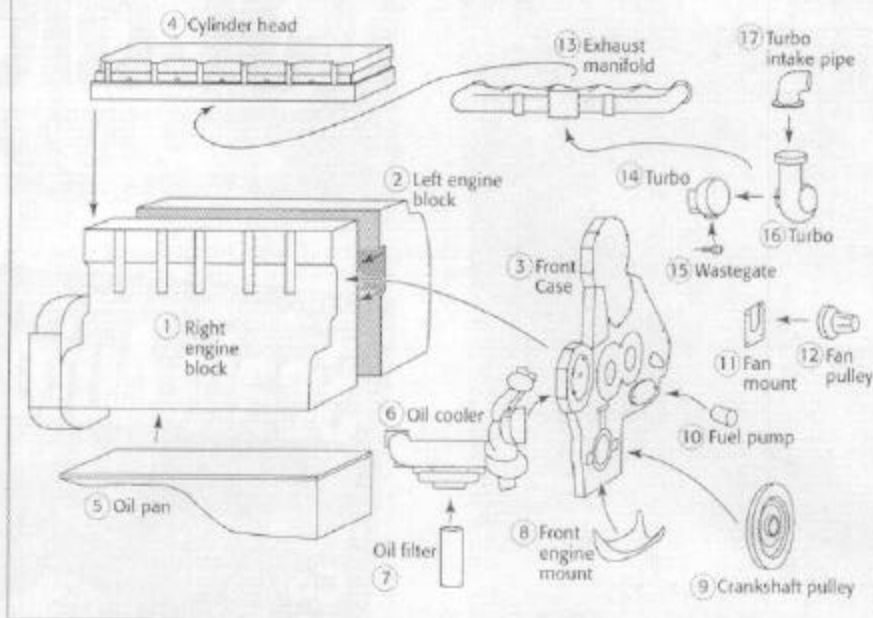

Master braided line no. 1303 for the main electrical harness. For best results, use a quick-setting, metal-to-metal cement during this assembly sequence.

Following Figure 3, drill a .020-inch diameter hole 1/16-inch-deep at the location indicated for each sensor. Notice that the coolant temperature sensor is located on the oil cooler, part no. 6.

Refer to Figure 1 and

Photo 3 to view this part. The oil cooler, along with its coolant temperature sensor and electrical harness connection, will be installed later.

The injector connector is positioned toward the front of the valve cover in the CFC kit as shown in Photo 3. I used the CFC engine kit's injector connector location for this article, but the connector position along the valve cover is optional. Drill a 1/16-inch deep hole into the injector connector with a .035-inch diameter bit.

Next, drill another .035-inch diameter hole through the center of a 1/16-inch length of no. MS-60 Plastruct square plastic strip. Cement this strip to the ECM's top connector as shown in Figure 3. Orient the strip with the previously drilled .035-inch diameter hole parallel to the side of the engine. Then, cement a 1-1/2-inch-long piece of Detail Master no. 1303 braided line

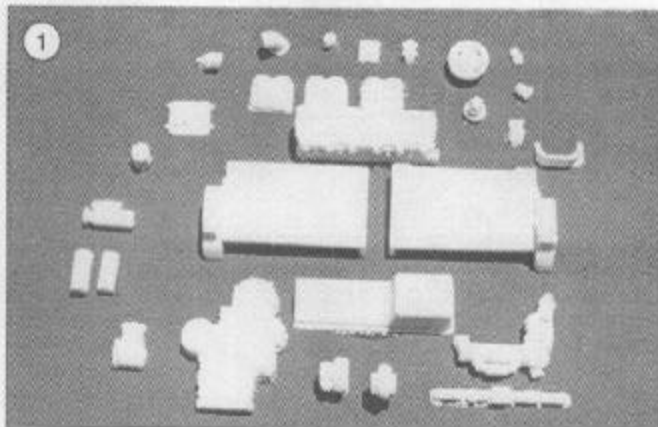

from the hole in the injector connector to the hole in the plastic strip on top of the ECM, as shown in Photo 2.

Now it's time to install the engine sensors. Cut one 2-inch-long, and seven 1-inch-long pieces of Detail Master braided line (part no. 1301). Next, slide a Detail Master adapter fitting (part no. 3043) onto one end of the 2-inch-long piece and six of the 1-inch-long pieces. Place two Detail Master part no. 3043 adapter fittings onto one end of the seventh 1-inch piece of braided line. Stack these adapters and cement them together, forming a double fitting that will simulate the engine speed/timing sensor.

Once all of the adapter fittings are in place, the braided lines can be attached to the engine. Cement the adapter fitting end of the 2-inch-long braided line to the oil pressure sensor location on

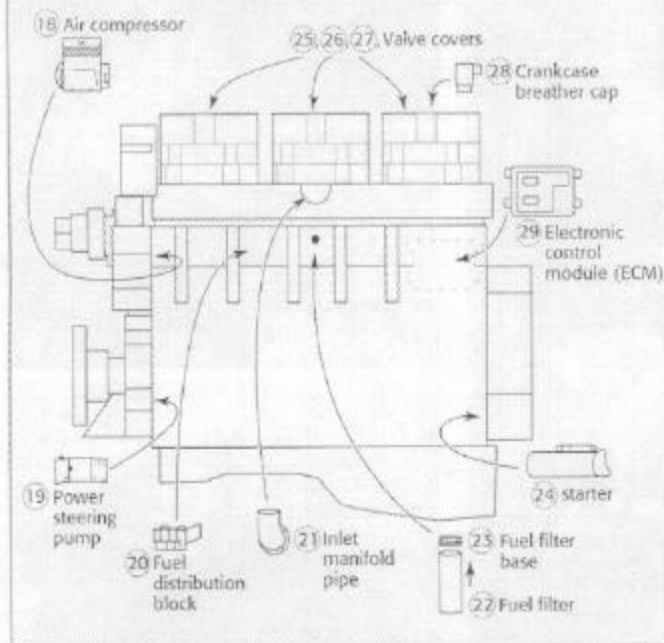
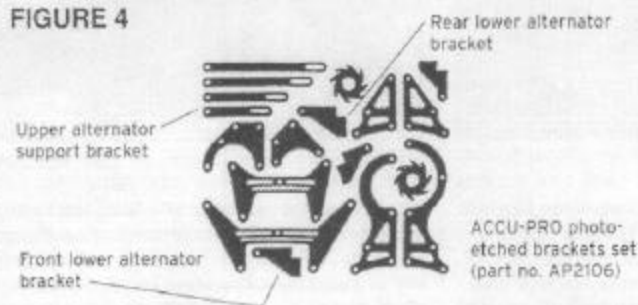
FIGURE 2 LEFT SIDE ENGINE COMPONENTS**FIGURE 4**

the right side of the engine block as shown in Figure 3. Also use Figure 3 as a guide to cement the double fitting on the 1-inch-long piece of braided line to the engine in the location indicated for the engine speed/timing sensor on the upper left side of the engine's front case. Then, follow Figure 3 and Photo 2 to cement the adapter fittings of the remaining 1-inch braided lines to the locations given for the atmospheric pressure sensor, fuel temperature sensor, intake manifold air temperature sensor, intake manifold pressure sensor, boost pressure sensor, and coolant temperature sensor on the oil cooler.

Next, fasten the braided lines to the electrical harness that runs from the injector connector to the ECM. The smaller leads feed into this larger electrical harness and should be cemented to its underside. Use Figure 3 and Photos 2 and 3 as guides for shortening, positioning, and cementing the sensor leads to the main electrical harness. We'll attach the coolant temp sensor lead to the oil pressure sensor when we install the oil cooler.

TURBOCHARGER INSTALLATION AND DETAILING. Begin by cementing the rear turbocharger half (part no. 14) and front turbocharger half (part no. 16) to the exhaust manifold (part no. 13) as shown in Figure 1. Refer to Figure 3 and Photo 4 to examine the mounting locations for the turbocharger oil supply and

turbocharger oil drain/return lines. We'll install the turbocharger wastegate (part no. 15) later. Use a .032-inch diameter bit to drill a hole into the right side of the engine block next to the oil cooler's rear mounting block (this hole is also shown in Photo 3). Then, drill another .032-inch diameter hole into the bottom of the narrow section between the turbocharger's halves. These holes are for the turbocharger oil return line.

Next, use a .020-inch diameter bit and drill a hole 1/32-inch deep into the outer right side of the block that is molded onto the top of the turbocharger's front half. Now refer to Photo 4 and Figure 3 and examine the base mount of the turbocharger oil supply line. Cut a .040-inch thick Plastruct square styrene strip (part no. MS-40) to a length of 1/8 inch, then cement the 1/8-inch-long square strip to the right side of the engine block as shown.

Detail Master fitting line no. 1313 will represent the turbocharger oil drain line, while DM no. 1311 will depict the turbocharger oil supply line. Starting with the turbo drain line, cut one piece of no. 1313 fitting line to a length of 3/4 inch. Cement this line into the previously drilled .032-inch diameter holes designated for the turbo drain line. Route the turbo drain line from the bottom center of the turbo to the hole in the side of the engine block next to the oil cooler mounting base. Be sure to tuck this drain line close to, but not against, the side of the engine.

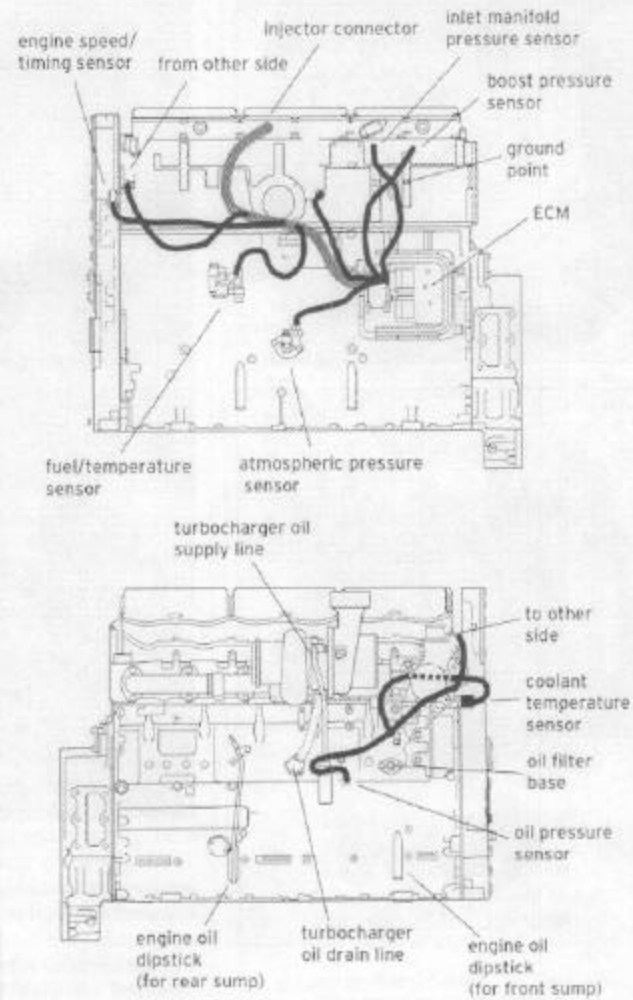
FIGURE 3 ENGINE SENSOR LEAD ROUTING

Cut a 1-inch-long piece of Detail Master no. 1311 fitting line and cement a Detail Master adapter fitting (part no. 3041) to one end. Refer again to Photo 4 and Figure 3 and cement the turbocharger oil supply line to the top of the turbo. Route the line over the outside of the turbo between its two halves and down to the top edge of the previously installed .040-inch-thick square plastic strip. Complete the turbocharger oil supply line by cementing the adapter fitting to the .040-inch plastic strip.

Once the turbocharger oil supply and drain lines are fixed in place, cement the oil cooler (part no. 6), with the coolant temperature sensor in place, onto the engine as shown in Figure 1 and Photo 5. The electrical lead from the coolant temperature sensor should be cemented to the electrical harness from the oil pressure sensor at this time.

The final part of the turbocharger to be installed is the wastegate (part no. 15). Refer to Figure 1 and Photo 5 to examine the wastegate's mounting location. To enhance wastegate detail, I also chose to add the actuator linkage and air inlet air line shown in Photo 5.

Referring to Figure 1, cement the wastegate to the underside of the rear turbocharger half. After the cement dries, cut the molded-in actuator rod from the wastegate mounting plate with a hobby knife. Next, drill a .030-inch diameter hole 1/32-inch-deep into the flat plate molded

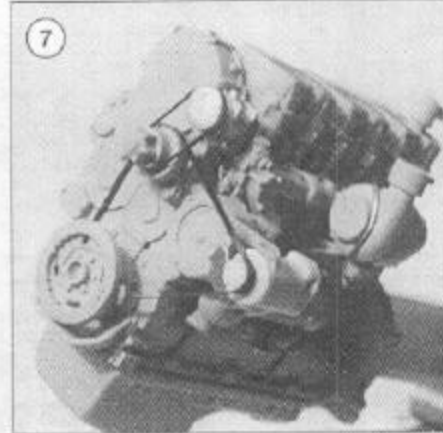
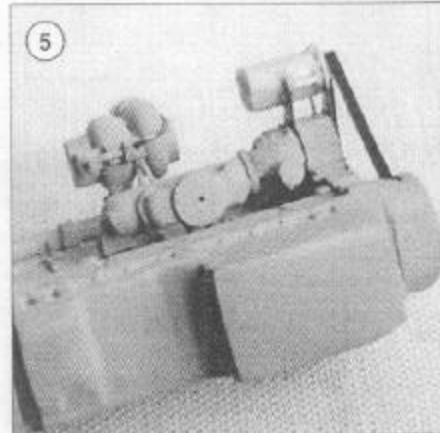
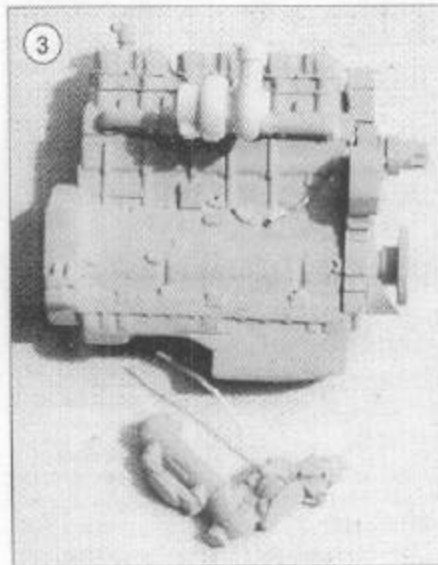
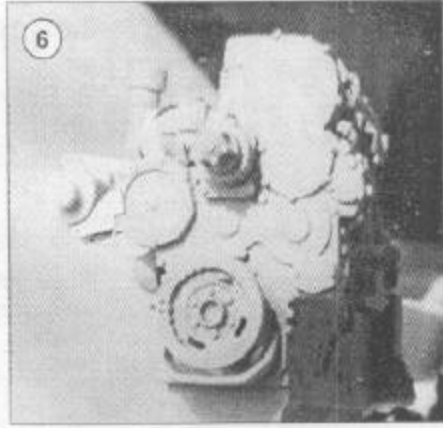
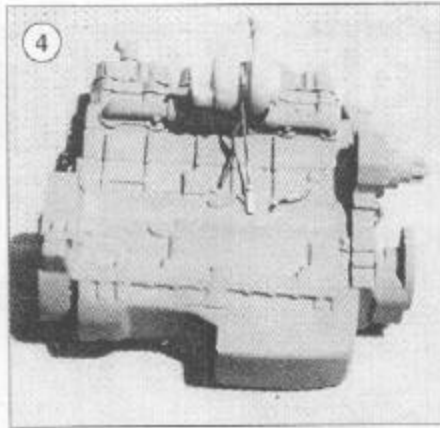
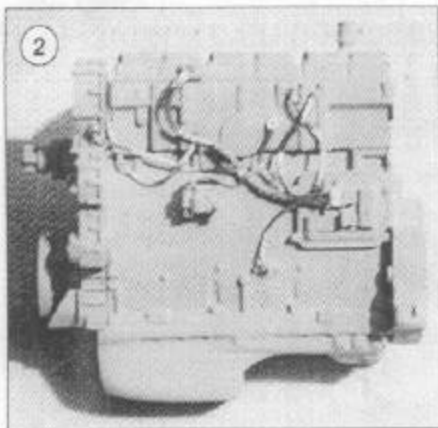

onto the underside of the exhaust port on the rear turbocharger half. Then, cut 5/32-inch and 3/32-inch long sections of .030-inch-thick Plastruct round strip (part no. MR-30). Cement the 5/32-inch piece in place so it butts up against both the running from the wastegate mounting bracket to the rear edge of the wastegate itself. This piece represents the new wastegate actuator rod. Now cement the 3/32-inch piece into the hole in the underside of the rear turbocharger half to depict the actuator lever rod. At this point, refer to Photo 5 and cement an "L"-shaped lever between the wastegate actuator rod and the actuator lever rod. I used a photoetched lever from Detail Master's Carburetor Linkage & Hardware kit (item no. 2420).

Complete the turbocharger installation by drilling a .025-inch diameter hole 1/32-inch deep into the outer front edge of the wastegate, and another into the top center of the exhaust manifold. Then, following Photo 5, cement a 7/8-inch piece of .020-inch solder wire from the hole in the wastegate to the hole in the exhaust manifold.

ALTERNATOR AND A/C COMPRESSOR INSTALLATION AND DETAILING. Since this kit doesn't come with an alternator, I decided to use a cast-resin Delco alternator (part no. EP-10) from Clint Freeman Components. For the A/C pump and its photoetched mounting brackets, I used parts that were offered by Accu-Pro, but are no longer available. However, Figure 4 can be used as a template for scratchbuilding the alter-

nator brackets from thin sheet plastic or aluminum. I also used an Accu-Pro street rod A/C compressor (part no. AP-4003) for this project, but an acceptable substitute item will have to be kitbashed, scavenged from an aftermarket detailing kit, or scratchbuilt.

Before starting the installation process, take time to examine Photos 6 and 7, as well as Figure 4. See Photo 6 for a view of the alternator and its mounting brackets attached to the engine's front case. Photo 7 shows how the A/C compressor is mounted to the engine, as well as how the two accessory drive belts should line up.

Attach the front and rear lower alternator brackets shown in Figure 4 to the engine as indicated in Photo 6. Cement one bracket to the front side of the engine's front case next to the accessory drive housing, then align the second bracket with the first and cement it in place on the rear edge of the front case. Next, cement the CFC alternator (part no. EP-10) to the front lower alternator bracket. The lower alternator mount should be on the inside of the front lower bracket.

Now cut a small piece of .010-inch thick sheet plastic and shape it to duplicate the mounting flange that is molded to the front of the alternator. Cement this flange to the inside of the rear lower bracket and then to the bottom of the alternator housing. Form the alternator's lower mounting bolt from a 1/8-inch-long piece of .030-inch diameter Plastruct rod (part no. MR-30), and cement it between the two lower alternator mounting flanges.

At this point, we can install the upper alternator support bracket shown in Figure 4. Photo 6 shows where to cement the upper alternator support bracket to the top alternator mount and the front accessory drive case. To complete the alter-

nator mounting, cement small plastic bolt heads and nuts onto the brackets to simulate mounting bolts.

To install the A/C compressor, first examine Photo 7, then cut a piece of Plastruct Fineline plastic angle (part no. AFS-6) to a length of 1/4 inch. Cement this angled plastic piece to the ledge on the engine's front case directly above the fan pulley mount (part no. 11) and the fan pulley (part no. 12). After the angled plastic is in place, cement the A/C compressor to it as indicated in Photo 7. Make sure the A/C compressor pulley lines up with the front pulley that is molded to the fan pulley. You can use pieces of black electrical tape to simulate the drive belts. Make the alternator belt 3/32-inch wide and the A/C pump belt 1/16-inch wide (only the widths are given here because the lengths of the drive belts will vary in each application).

Check your progress by comparing the engine you've built to the CFC Caterpillar 3406E shown in Photos 2 and 7.

Next issue, we'll detail the left side of the engine and complete the project.

CM

Clint Freeman Components
180 Lanesview Ave., Dept. CM
Niles, OH 44446
LSASE for catalog

Detail Master
P.O. Box 1465-A, Dept. CM
Sterling, VA 20167
\$3 for catalog, refundable with order

Plastruct, Inc.
1020 Wallace Pl., Dept. CM
City of Industry, CA 91749
\$2 for catalog